

0100330 - 0100345

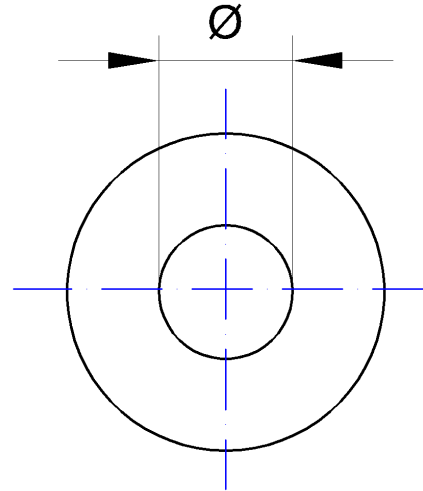
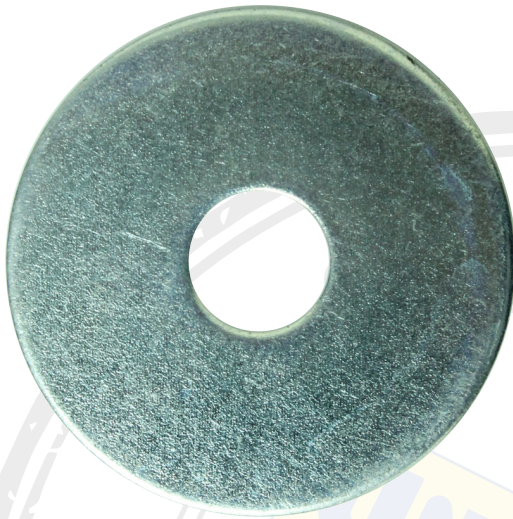

DESCRIPCIÓN

Arandela plana con diámetro externo variado manteniendo un mismo diámetro interno. De uso general, comunmente utilizadas en reparaciones de carrocería de autos, en láminas de metal, para plomería y para aplicaciones eléctricas.

ESPECIFICACIONES

CÓDIGO	MEDIDA	Ø INTERNO		Ø EXTERNO	
		PULGADAS	MM	PULGADAS	MM
0100330	3/16x1"	3/16"	4.76	1"	25.4
0100332	3/16x1 1/4"	3/16"	4.76	1 1/4"	31.75
0100333	1/4x1"	1/4"	6.35	1"	25.4
0100335	1/4x1 1/4"	1/4"	6.35	1 1/4"	31.75
0100337	1/4x1 1/2"	1/4"	6.35	1 1/2"	38.1
0100338	5/16x1 1/4"	5/16"	7.93	1 1/4"	31.75
0100340	5/16x1 1/2"	5/16"	7.93	1 1/2"	38.1
0100341	3/8x1 1/2"	3/8"	9.52	1 1/2"	38.1
0100343	3/8x2"	3/8"	9.52	2"	50.8
0100344	1/2"x1 1/2"	1/2"	12.70	1 1/2"	38.1
0100345	1/2"x2"	1/2"	12.70	2"	50.8

MATERIAL



GRADO

